



US 20200094076A1

(19) **United States**

(12) **Patent Application Publication**
CAVUTO et al.

(10) **Pub. No.: US 2020/0094076 A1**

(43) **Pub. Date: Mar. 26, 2020**

(54) **COMPACT PROTON BEAM ENERGY MODULATOR**

G21K 5/04 (2006.01)

G06T 11/00 (2006.01)

(71) Applicant: **Massachusetts Institute of Technology**, Cambridge, MA (US)

(52) **U.S. Cl.**

CPC *A61N 5/1067* (2013.01); *A61B 6/5205* (2013.01); *A61N 2005/1087* (2013.01); *G06T 11/008* (2013.01); *G21K 5/04* (2013.01)

(72) Inventors: **Matthew L. CAVUTO**, Skillman, NJ (US); **Neerja AGGARWAL**, Cambridge, MA (US); **Melissa LI**, Johns Creek, GA (US); **Nathaniel H. RODMAN**, Corvallis, OR (US)

(57) **ABSTRACT**

(21) Appl. No.: **16/483,605**

(22) PCT Filed: **Apr. 6, 2018**

(86) PCT No.: **PCT/US2018/026443**

§ 371 (c)(1),

(2) Date: **Aug. 5, 2019**

Related U.S. Application Data

(60) Provisional application No. 62/482,743, filed on Apr. 7, 2017.

Publication Classification

(51) **Int. Cl.**

A61N 5/10 (2006.01)

A61B 6/00 (2006.01)

A proton beam imaging system includes: a proton beam generator to generate a proton beam; a proton beam modulator through which the proton beam passes positioned between the proton beam generator and an image target; and a proton beam detector positioned to detect the proton beam existing the image target; wherein the proton beam modulator comprises: a rotating wheel having an axis of rotation positioned so that the proton beam passes through the axis of rotation and the axis of rotation is perpendicular to the proton beam; a first modulating portion comprising a first material portion and a second material portion through which a proton beam passes; and a second modulating portion comprising a third material portion and a fourth material portion through with the proton beam passes; wherein the first and second wedges are positioned opposite each other on the rotating wheel.

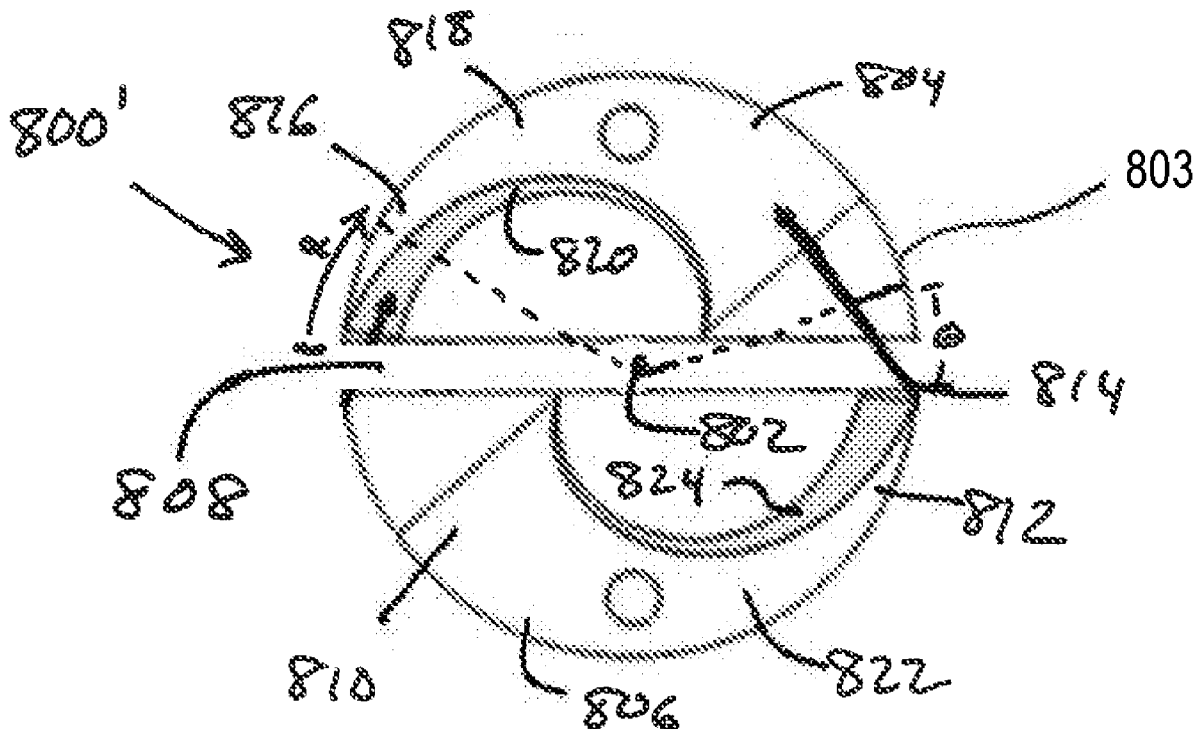

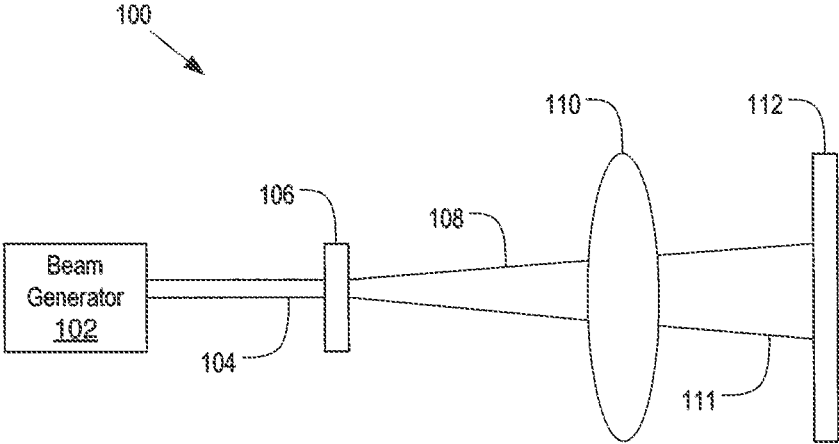

FIG. 1

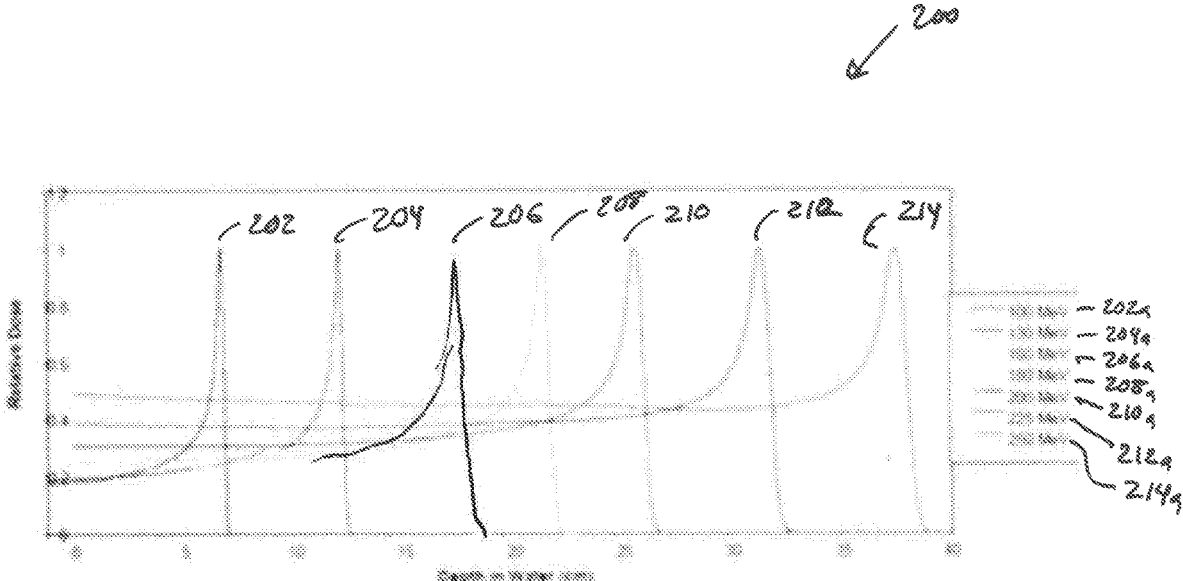

FIG. 2

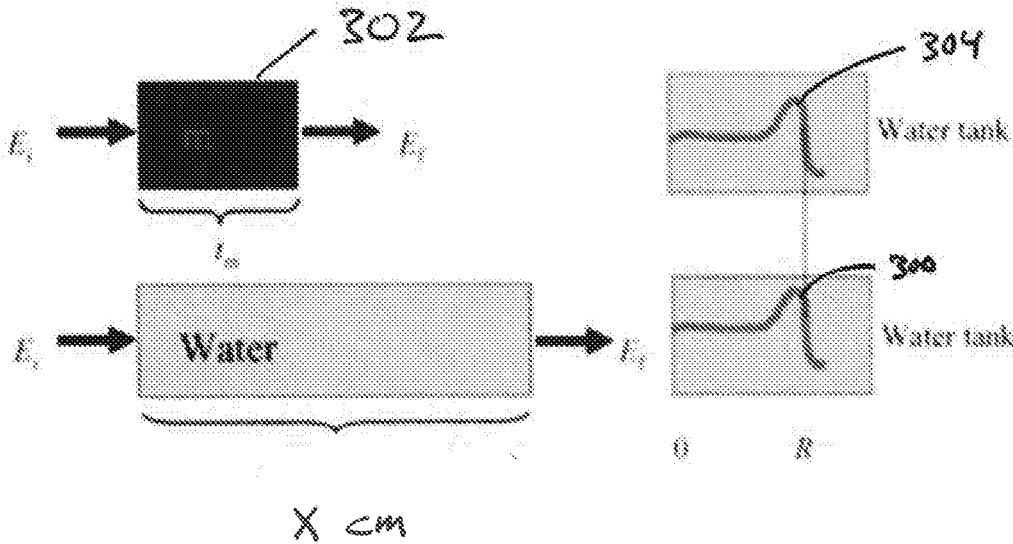

FIG. 3

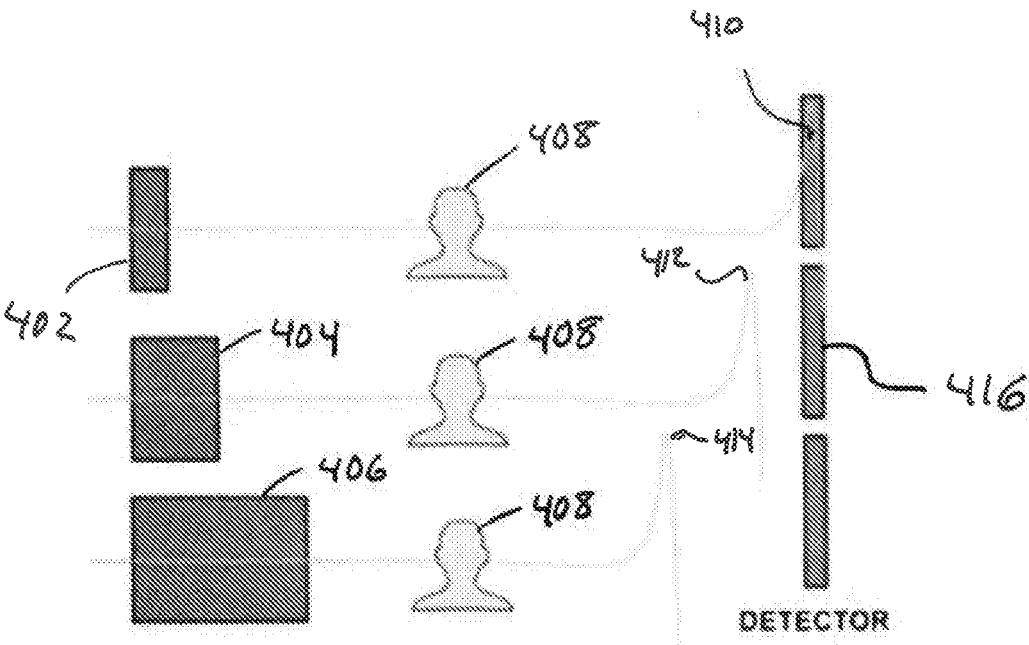

FIG. 4

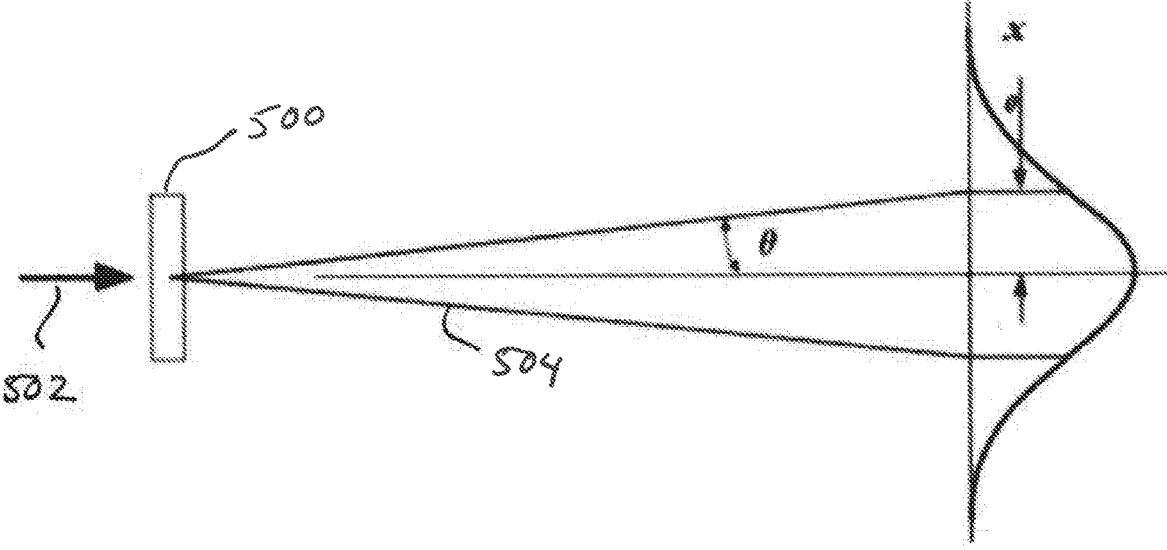

FIG. 5

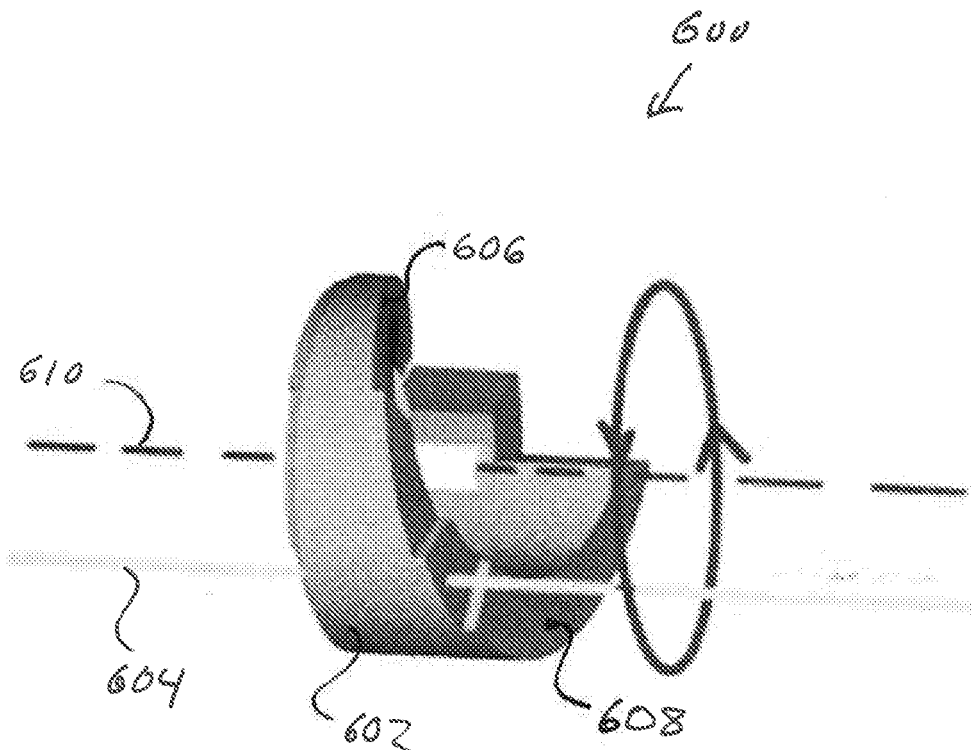

FIG. 6
PRIOR ART

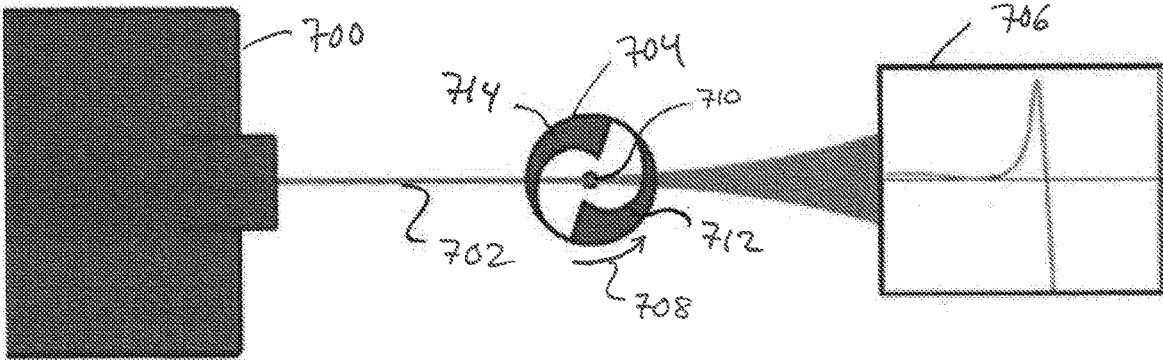
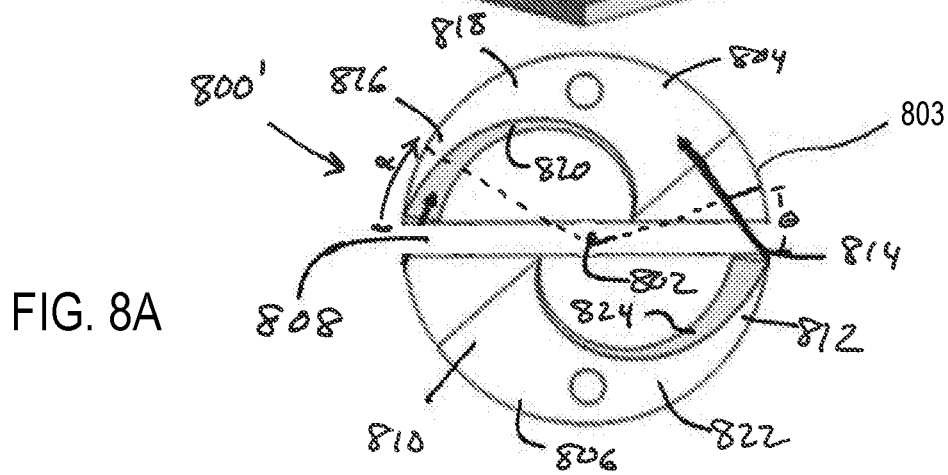
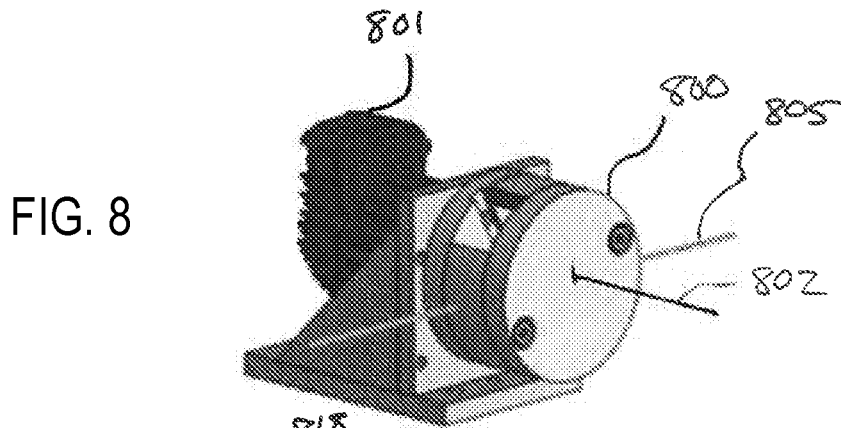

FIG. 7



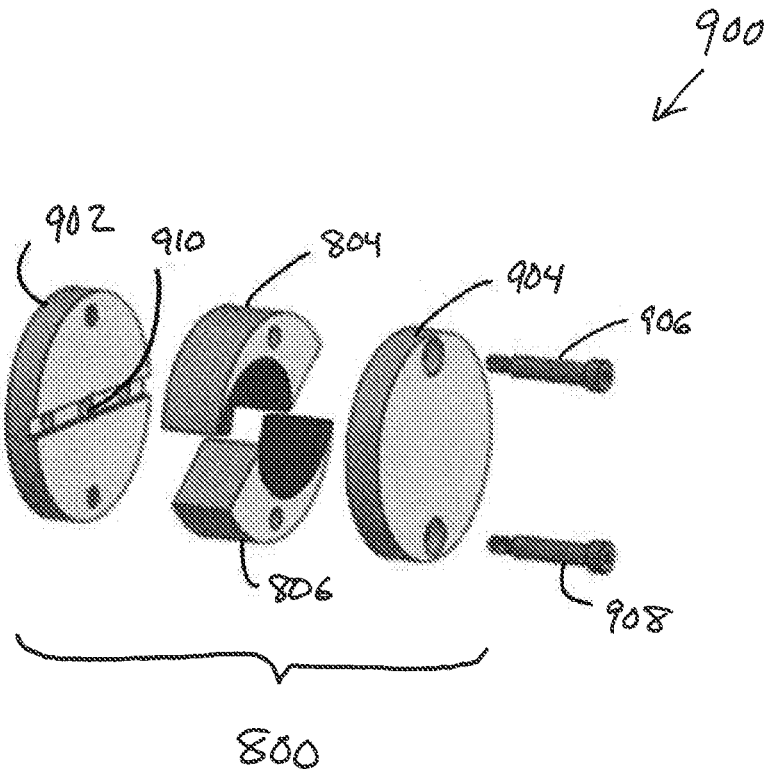

FIG. 9

1000
↓

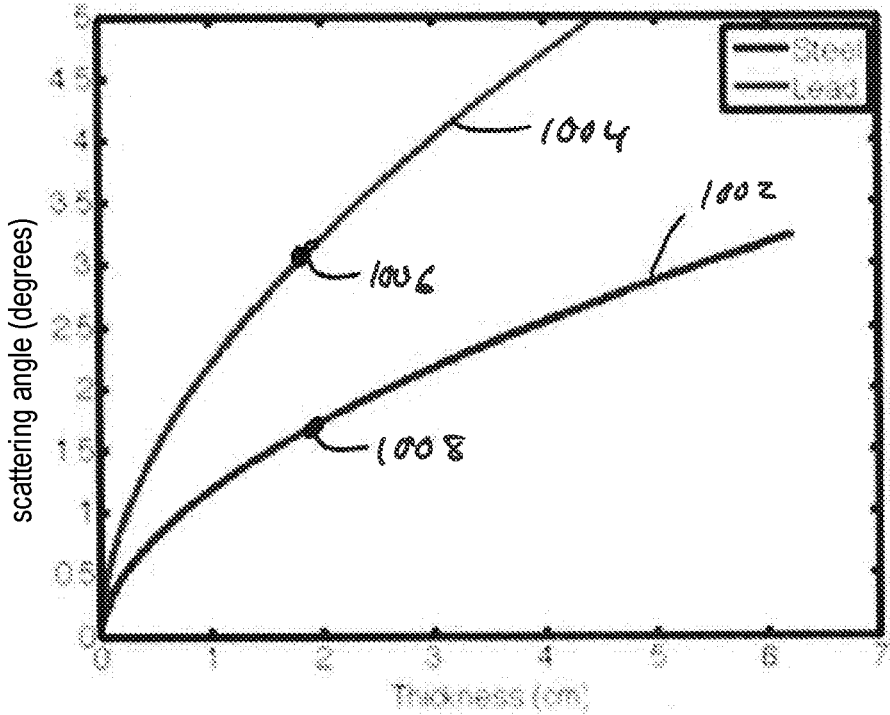
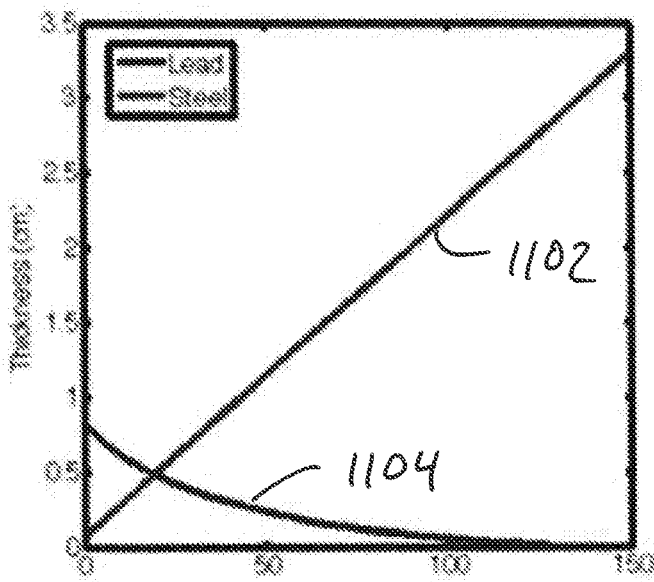

FIG. 10



1100
↙

FIG. 11

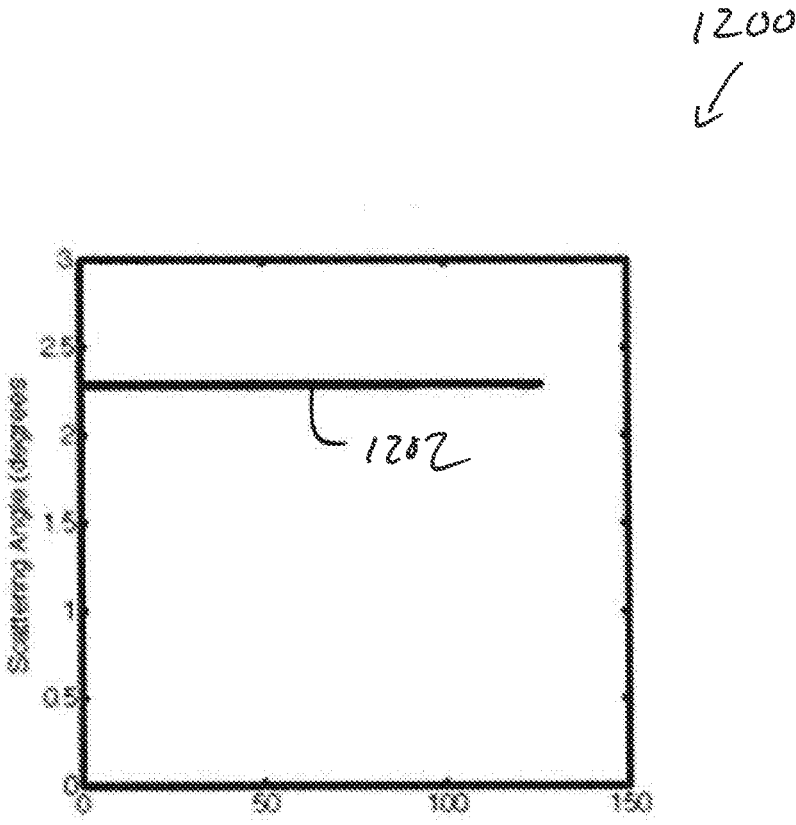

FIG. 12

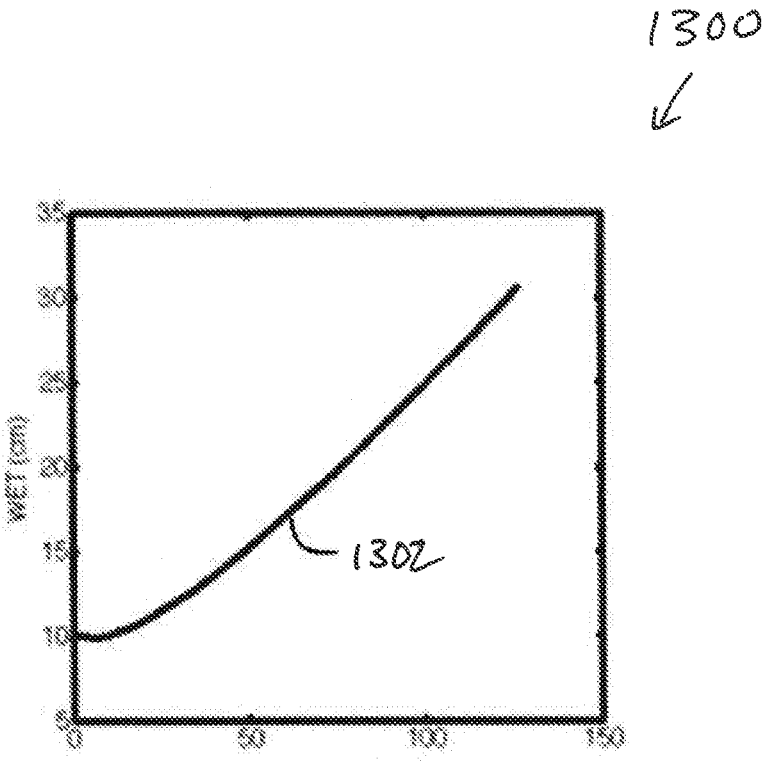

FIG. 13

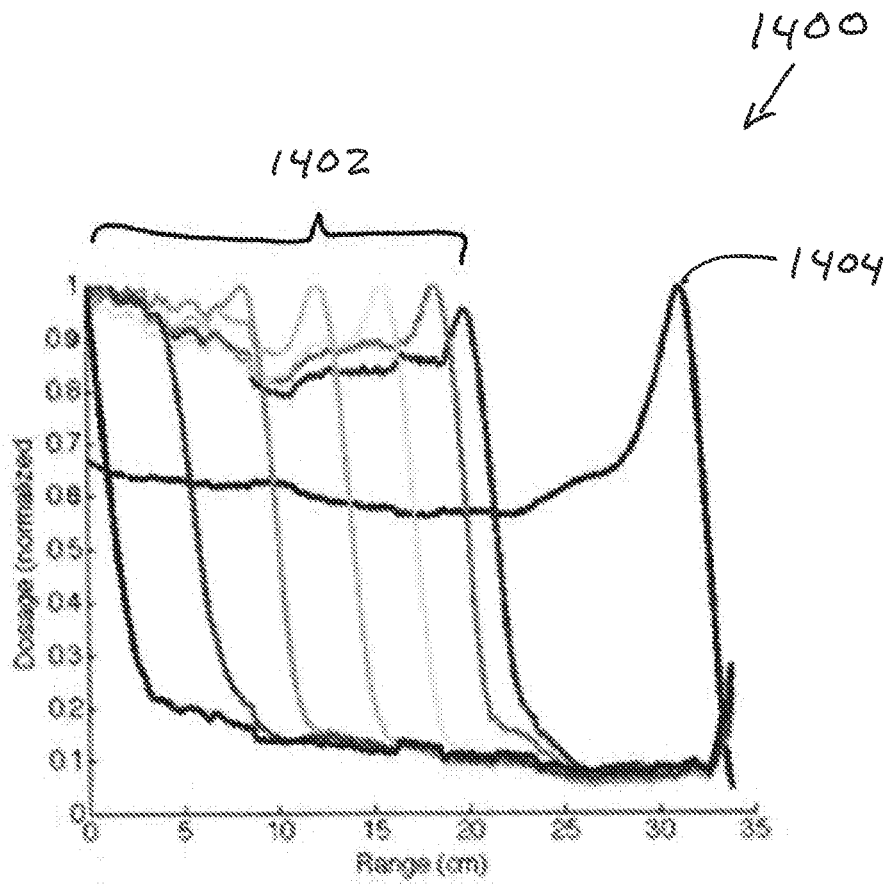

FIG. 14

COMPACT PROTON BEAM ENERGY MODULATOR

RELATED APPLICATIONS

[0001] This patent claims priority to and benefit of U.S. Provisional Patent Application No. 62/482,743 (filed Apr. 7, 2017), which is incorporated here by reference in its entirety.

BACKGROUND

[0002] Proton beams are used in medical applications to apply radiation treatment to areas of a patient's body. For example, a proton beam may be applied to a cancerous tumor with more precision than standard radiation techniques. Using a proton beam for treatment may reduce or eliminate radiation damage to tissues surrounding the targeted tumors. This is due, at least in part, to a proton's ability to deliver a radiation dose to a very small and condensed area compared to other radiation delivery techniques.

[0003] Treatment consists of directing high energy protons into a patient's body such that the protons deposit their radiation energy inside the tumor. Prior to treatment, the tumor and surrounding area must be imaged. Typically, photon-based imaging techniques like x-ray have been used. However, the photons used by these techniques differ from the protons used for delivery of treatment and interact with the tissue differently. Thus, using a photon-based imaging system to guide the proton-based treatment may introduce a margin of error.

SUMMARY

[0004] For certain applications, it may be beneficial to provide a proton beam modulator to meet one or more of the following goals: a minimum modulation range of 25 cm WET, a maximum period of full range modulation less than 300 ms, a constant scattering angle during modulation, a minimum energy step resolution of 2 mm WET, a maximum random error of less than 0.5 mm WET, the ability to stop the beam entirely once per cycle period, a modulator size that may fit within a 10 cm cube, the ability to accommodate a 0.5 cm beam diameter, balanced weight around an axis of rotation to minimize vibration during rotation, ability to operate in a vacuum, and the ability to let a proton beam pass through the modulator unobstructed.

[0005] In embodiments, a proton beam modulator includes a first modulating portion comprising a first material portion and a second material portion through which a proton beam passes; and a second modulating portion comprising a third material portion and a fourth material portion through which the proton beam passes; wherein the first and second modulating portions are positioned opposite each other on a rotating wheel.

[0006] One or more of the following features may be included:

[0007] The rotating wheel may be positioned so that the proton beam passes through a center of rotation of the rotating wheel.

[0008] The rotating wheel may be positioned so that an axis of rotation of the rotating wheel is perpendicular to the proton beam.

[0009] The first modulating portion and the second modulating portion may be positioned to create an open channel through the modulator so that, when the channel is parallel

to the proton beam, the proton beam can pass through the open channel without passing through the first and second modulating portion.

[0010] The first modulating portion may have a wedge shape.

[0011] The first material portion and the second material portion are arranged radially from a center of rotation of the wheel so that the second material portion is inside the first material portion.

[0012] A thickness of the wedge shape may decrease along an angular coordinate of the wedge shape.

[0013] A thickness of the first material portion may decrease along the angular coordinate of the wedge shape and a thickness of the second material portion may increase along the angular coordinate of the wedge shape.

[0014] The combination of the first, second, third, and fourth material portions may modulate an energy level of the proton beam and a scattering of the proton beam.

[0015] The combination of the first, second, third, and fourth material portions may modulate the energy level of the proton beam such that the energy level of the proton beam changes as the modulator rotates.

[0016] The first and second modulating portions are each provided having a wedge shape.

[0017] The first and second modulating portions are each provided having a wedge shape and produce an energy modulation in the range of about 12 cm WET to about 32 cm WET.

[0018] The combination of the first, second, third, and fourth material portions may modulate the scattering of the proton beam so that the scattering remains substantially constant as the modulator rotates.

[0019] A circular plate may be positioned so that the first modulating portion and the second modulating portion are sandwiched between the rotating wheel and the circular plate.

[0020] The first and second modulating portions may be removable from the rotating wheel and the circular plate.

[0021] The first and third material portions may comprise stainless-steel.

[0022] The second and fourth material portions may comprise lead.

[0023] The rotating wheel may have a diameter of 10 cm or less.

[0024] In another embodiment, a proton beam imaging system includes: a proton beam generator to generate a proton beam; a proton beam modulator through which the proton beam passes positioned between the proton beam generator and an image target; and a proton beam detector positioned to detect the proton beam existing the image target; wherein the proton beam modulator comprises: a rotating wheel having an axis of rotation positioned so that the proton beam passes through the axis of rotation and the axis of rotation is perpendicular to the proton beam; a first modulating portion comprising a first material portion and a second material portion through which a proton beam passes; and a second modulating portion comprising a third material portion and a fourth material portion through which the proton beam passes; wherein the first and second wedges are positioned opposite each other on the rotating wheel.

[0025] One or more of the following feature may be included:

[0026] The first and third material portions may comprise stainless-steel, and the second and fourth material portions may comprise lead.

[0027] The first and third material portions may comprise a wedge shape having a varying thickness to modulate an energy level of the proton beam as the proton beam modulator rotates, wherein the proton beam may be modulated to have a varying energy level as the proton beam modulator rotates.

[0028] The second and fourth material portions may comprise a wedge shape having a varying thickness to modulate a degree of scattering of the proton beam as the proton beam modulator rotates, wherein the proton beam may be modulated to have a substantially constant degree of scattering as the proton beam modulator rotates.

[0029] The proton beam imaging system may comprise a gantry portion, wherein the proton beam modulator is situated within the gantry portion.

[0030] In embodiments, a proton beam modulator includes a plurality of wedge-shaped modulating portions, each of the plurality of wedge-shaped modulating portions comprising a first material portion and a second material portion configured such that in response to a proton beam incident thereon, at least portions of the proton beam are capable of passing therethrough and wherein the of the plurality of wedge-shaped modulating portions are disposed in spatial relation such that the plurality of wedge-shaped modulating portions define an axis of rotation positioned such that an axis along which a proton beam is aligned is perpendicular to the axis of rotation defined by the plurality of wedge-shaped modulating portions.

[0031] In embodiments, the plurality of wedge-shaped modulating portions are provided as a pair of modulating portions positioned opposite each and define an axis of rotation positioned such that an axis along which a proton beam is aligned is perpendicular to the axis of rotation defined by the pair of wedge-shaped modulating portions.

BRIEF DESCRIPTION OF THE DRAWINGS

[0032] The foregoing features may be more fully understood from the following description of the drawings. The drawings aid in explaining and understanding the disclosed technology. Since it is often impractical or impossible to illustrate and describe every possible embodiment, the provided figures depict one or more exemplary embodiments. Accordingly, the figures are not intended to limit the scope of the invention. Like numbers in the figures denote like elements.

[0033] FIG. 1 is a block diagram of a proton beam imaging system.

[0034] FIG. 2 is a graph of radiation from proton beams.

[0035] FIG. 3 is a block diagram illustrating water-equivalent thickness (WET).

[0036] FIG. 4 is a block diagram illustration energy modulation of a proton beam.

[0037] FIG. 5 is a diagram illustrating scattering of a proton beam.

[0038] FIG. 6 is an isometric view of a proton beam modulator.

[0039] FIG. 7 is a block diagram of a proton beam imaging system including a proton beam modulator.

[0040] FIG. 8 is an isometric view of a proton beam modulator coupled to a drive system.

[0041] FIG. 8A is a side view of a proton beam modulator which may be the same as or similar to the proton beam modulator of FIG. 8.

[0042] FIG. 9 is an isometric, exploded view of a proton beam modulator assembly.

[0043] FIG. 10 is a graph of proton beam scattering versus material thickness.

[0044] FIG. 11 is a graph of material thicknesses versus angular position of a proton beam modulator.

[0045] FIG. 12 is a graph of proton beam scattering versus angular position of a proton beam modulator.

[0046] FIG. 13 is a graph of a WET characteristic versus angular position of a proton beam modulator.

[0047] FIG. 14 is a graph of radiation delivery of a proton beam imaging system.

DETAILED DESCRIPTION

[0048] FIG. 1 is a block diagram of a proton beam imaging system 100. Proton beam imaging system 100 includes a beam generator 102 which generates a proton beam 104. Proton beam 104 may be a columnar beam with a fixed or variable energy level.

[0049] Modulator 106 may comprise a quantity of material through which proton beam 104 passes. As it passes through, proton beam 104 may lose energy due to dissipation or blocking by modulator 106. Modulator 106 may also scatter the protons in beam 104. As a result, the incident beam 108 that passes through modulator 106 may have a lower energy level (due to dissipation) and a wider area (due to scattering) than proton beam 104.

[0050] Incident beam 108 may then pass through target 110, which may also affect the energy level and scattering profile of beam 108. In embodiments, target 110 may be the item to be imaged by proton imaging system 100. If proton imaging system 100 is used in a medical imaging application, for example, target 110 may be a portion of a patient's body.

[0051] A proton detector array 112 may detect proton beam 111 exiting target 110. Once detected, the signals produced by proton detector array 112 may be processed (e.g. by a general purpose or image processor) to produce an image of target 110.

[0052] Proton beam generator 102 may be housed in a gantry (not shown). For example, if the proton beam imaging system is a medical imaging system, a gantry may be suspended in or around a patient bed or examination table. In embodiments, the proton beam modulator may also be situated in the gantry so that proton beam 104 exits the gantry having already been modulated.

[0053] Referring to FIG. 2, materials through which a proton passes may be qualified with a water equivalent thickness ("WET") that indicates how much energy the material will dissipate from the proton as the proton passes through the material. Graph 200 illustrates the WET concept. The horizontal axis represents depth (in cm) through which a proton travels through water. The vertical axis represents radiation given off by the proton.

[0054] When the energy of a proton is almost depleted, the proton delivers a maximum dosage of radiation called a Bragg peak. Peaks (e.g. peaks 202-214) represent the Bragg peaks of protons having various levels of initial energy. A proton with greater initial energy will travel further through

water than a proton with relatively less initial energy. For example, peak **202**, which occurs at about 6 cm of water depth, results from a proton having 100 MeV of energy (as shown by reference number **202a**). Peak **214**, which occurs at about 37 cm of water depth, results from a proton having 250 MeV of energy (as shown by reference number **214a**). The other peaks result from protons having energy levels between 100 MeV and 250 MeV, as indicated by their respective energy levels labeled **202a-214a**.

[0055] Referring to FIG. 3, materials may be qualified by their WET rating. In FIG. 3, a proton passing through X cm of water results in Bragg peak **300**. Similarly, a proton passing through material **302** results in Bragg peak **304**. Because Bragg peaks **300** and **304** are the same, material **302** may be said to have a WET value of X cm.

[0056] FIG. 4 is a diagram that illustrates the effect of modulators having different WET values. In this example, modulator **402** may have the smallest WET value, modulator **404** may have an intermediate WET value, and modulator **406** may have the largest WET value of the three modulators shown. As a result, protons that pass through modulator **402** may exit modulator **402** with a higher energy level than protons that pass through modulator **404** because modulator **404** will dissipate more energy from the protons than modulator **402**. Similarly, protons that pass through modulator **404** may exit modulator **404** with a higher energy level than protons that pass through modulator **406**. Because the protons have different levels, their respective Bragg peaks will occur at different locations. The proton that passes through modulator **402** has the highest energy level, thus its Bragg peak **410** occurs at a location further than Bragg peak **412** and **414**. The proton that passes through modulator **404** has an intermediate energy level, thus its Bragg peak **412** occurs at a location between Bragg peaks **410** and **414**. And the proton that passes through modulator **406** has the lowest energy, thus its Bragg peak **414** occurs before Bragg peaks **410** and **412**.

[0057] The variation in proton energy levels and the resulting difference in Bragg peak location can be detected by detector **416** to produce an image of patient **408**.

[0058] One reason to modulate the proton beam is so that the proton beam imaging system can create a dosage rate function on the proton detector **416** for each pixel of the created image. The dosage rate function is the curve representing the dose measured by the detector pixels vs time. It is created by modulating the incident proton beam energy. The dose measured on the detector is maximum when the Bragg peak lands on the detector **410** and is produced by the modulator having a WET **402**. As the modulator varies in WET **404** & **406** vs time, the dose on the detector varies in time.

[0059] The material and tissue of patient **408** that the proton beam passes through may have different water equivalent path lengths (WEPL). For example, bone may have a different WEPL than organ tissue, which may have a different WEPL than muscle tissue, etc. These different tissues may dissipate different amounts of energy from the proton beam, which may result in different dosage rate functions at the pixels receiving protons passing through that portion of the patient. These dosage rate functions at each pixel may be compared to calibration data consisting of dosage rate functions for known WET values. Thus, to create an accurate image, it is desirable to use this comparison to calculate the WEPL (water equivalent path length)

from each pixel and reconstruct an overall image based on WEPL vs x and y. This WEPL image may result in a more accurate calculation of the relative stopping power (RSP) of the proton beam for treatment than current conversion from computed tomography (CT) images.

[0060] FIG. 5 is a diagram of proton beam scattering by a modulator **500**. Along with energy dissipation described above, a proton beam may scatter, i.e. spread out, as it passes through material such as modulator **500**. Beam **502** may be a columnar beam when it enters modulator **500**. However, proton beam **504** exiting modulator **500** may be scattered by an angle θ . This may cause a lateral spread x.

[0061] Referring to FIG. 6, a proton beam modulator **600** of the prior art includes a cylindrical body **602** through which proton beam **604** passes. Body **602** has a thickness that varies around the body's circumference. For example, body **602** is thicker at point **608** than it is at point **606**. If beam **604** passes through body **602** at point **608**, body **602** will dissipate more energy from beam **604** than if beam **604** passed through body **602** at point **606**. The scattering effect at points **606** and **608** may also be different.

[0062] Proton beam modulator **600** may rotate about an axis **610**, which may be parallel to and offset from proton beam **604**. As modulator **600** rotates, proton beam **604** will pass through portions of body **602** with varying thickness. Thus, as modulator **600** rotates, the energy of beam **604** will vary.

[0063] FIG. 7 is a block diagram of another embodiment of a proton beam imaging system. A proton beam generator **700** produces proton beam **702**, which passes through modulator **704**, through a target (not shown), and is detected by proton detector **706**.

[0064] Proton beam modulator **704** may be a cylindrical modulator that rotates while beam **702** passes through it. In embodiments, the axis of rotation of modulator **704** may be perpendicular to beam **702** (i.e. in a direction into or out of the page) so that modulator **704** rotates in the direction of arrow **708**. Also, modulator **704** may be positioned so that beam **702** passes through the center of rotation **710**.

[0065] Proton beam modulator **704** may include two material sections **712** and **714** positioned so that beam **702** passes through section **712** and **714** as it passes through modulator **704**. Material sections **712** and **714** may have variable thicknesses so that, as modulator **704** rotates, the thickness of the material that beam **702** passes through varies. As a result, as modulator **704** rotates, the thicker areas of material sections **712** and **714** will dissipate more energy from the proton beam and perform more scattering of the proton beam, so the energy level and scattering of beam **702** exiting the modulator will vary.

[0066] Referring to FIGS. 8 and 8A, a modulator assembly **800** is mounted, or otherwise coupled or secured to, a drive system **801**. In this illustrative embodiment, modulator assembly **800** is provided having a wheel-shape. Other shapes may, of course be used including but not limited to any regular or irregular geometric shape. Drive system **801** is capable of controlling the "spin" (i.e. the rate at which a modulator rotates around an axis of rotation) of at least a modulator **803** within modulator assembly **800**. Specifically, modulator **801** is coupled to a shaft (e.g. a motor shaft) or other mechanical structure (not visible in FIG. 8) and drive system **801** turns the modulator **801** at a controllable and

accurate rate of speed. In embodiments, drive system **801** is provided as a motor and modulator **801** is coupled to a motor shaft (not visible in FIG. **8**).

[**0067**] As shown, modulator assembly **800** is disposed relative to a proton beam generator such that an axis of rotation **802** of modulator assembly **800** is perpendicular to an axis **805** along which a proton beam is aligned. During operation, motor **801** may rotate at least modulator **803**. As a proton beam **805** passes through modulator assembly **800** (and in particular through modulators portions **804**, **806**), wedge-shaped modulators **804**, **806** (FIG. **8A**) intercept a proton beam **805**. The configuration of the wedge-shaped modulators **804**, **806** cause the energy level of proton beam **805** to vary after passing therethrough. Thus, the energy level of proton beam **805** may be varied during, for example, an imaging operation. The beam with varying energy levels may pass through a target (not shown in FIG. **8**) and be detected by a proton beam detector (also not shown in FIG. **8**). The detector may produce a signal representing the detected protons, which can be used by a processor to form an image of the target.

[**0068**] In embodiments, drive system **801** may be provided as a servo motor, or any other type of motor capable of precisely controlling the angular position and speed of rotation of the modulator within modulator assembly **800**. It should, of course, be appreciated that any type of motor capable of rotating the modulator may, of course, also be used.

[**0069**] In one illustrative embodiment, drive system **801** may rotate modulator **800** at about 15 to about 20 rpms (i.e. one rotation every three to four seconds) or faster. In other embodiments, drive system **801** may rotate modulator **800** at about 180 rpm (i.e. a period of about 300 ms) or faster. This allows the modulator to sweep the energy level from the highest to the lowest energy level (or vice versa) in the time that it takes a person to take a breath. This may be beneficial if, for example, the proton beam imaging system is collecting an image of a patient's lung or other movable body area. If the full sweep of modulation occurs within a few seconds, or within a few hundred milliseconds, the imaging system may be able to capture an image before much body movement has occurred.

[**0070**] Referring now to FIG. **8A** modulator **803** includes a plurality of material sections (with two wedge-shaped material sections **804** and **806** shown in the illustrative embodiment of FIG. **8A**) positioned about axis of rotation **802**. In embodiments, material sections may be placed symmetrically about axis of rotation **802** so that modulator **803** is balanced during rotation, which may help reduce rotational vibration. As beam **805** passes through material sections (e.g. material sections **804** and **806** in the illustrative embodiment of FIG. **8A**), the material sections may modulate and scatter beam **805** as described above.

[**0071**] The material sections may be provided having a shape such that when they are appropriately positioned, a straight, open channel **808** exists through modulator **803**. When modulator **803** is rotated so that channel **808** is parallel to beam **805**, beam **805** may pass through channel **808** without passing through the material sections. In other words, when channel **808** is parallel to beam **805**, beam **805** may pass through modulator **803** without being modulated. This may be useful if it is desired to use the same proton beam for imaging and radiation delivery. For example, modulator **803** can modulate the beam as it passes through

material sections **804** and **806** for imaging. Then, for radiation dosage delivery, modulator **800** may rotate to a position that allows beam **805** to pass through channel **808** without being modulated. In this position, the unmodulated proton beam **805** may be used to deliver doses of radiation that are higher in energy than the modulated beam to target tissue.

[**0072**] In some applications, lower proton beam energies are used for treatment than for imaging. For example, a beam with lower energy may deliver its Bragg peak (and its resulting energy) within the patient at the site of treatment, rather than passing through the patient to be detected by the proton detector. If a lower proton beam is needed for treatment, it may seem counterintuitive to use open channel **808** during treatment because open channel **808** does not dissipate energy from beam **805**. However, in embodiments, the proton beam treatment system may include another modulator specifically for modulating beam **805** during treatment. In these systems, the open channel **808** of modulator **800** may be used during treatment so that a separate treatment modular can be used to control the energy of beam **805** to deliver the proton beam's radiation to the treatment site within the patient.

[**0073**] In embodiments, material sections **804** and **806** may each have a curved wedge shape. The wedge shape may provide each material section with a thickness that varies along the length (e.g. along the shape) of each wedge. For example, material section **806** may have a thick end **810** and a thin end **812**. Likewise, material section **804** may have a thick end **814** and a thin end **816**. The thicker areas may provide more energy dissipation than the thin ends. Thus, a proton passing through thick portion **810** and thick portion **814** may exit modulator **803** with a lower energy level than a proton passing through thin portions **812** and **816**. As modulator **803** spins, the thickness of the material through which proton beam **805** varies, and thus the energy level of proton beam **805** exiting modulator **800** will vary.

[**0074**] Material section **804** may comprise a first material **818** and a second material **820** coupled together to form the shape of material section **804**. Similarly, material section **806** may comprise a first material **822** and a second material **824** coupled together to form the shape of material section **806**. In embodiments, material **818** and material **822** may be the same material. Likewise, material **820** and material **824** may be the same material. In other embodiments, the materials may vary.

[**0075**] Materials **818** and **820** of material section **804** may be chosen so that, as modulator **803** rotates, modulator **803** will vary the energy level of proton beam **805** across a desired energy range and also maintain a relatively constant scattering angle of proton beam **805**. For example, as proton beam **805** passes through thick portion **814** it will exit modulator **803** with less energy than when it passes through thin portion **816**. However, the scattering of proton beam **805** will remain relatively constant whether it passes through thick portion **814** or thin portion **816**. This effect can be achieved by the type of material and relative thicknesses chosen for material sections **818** and **820** (and material sections **822** and **824**).

[**0076**] Different materials have different WET characteristics, as shown in table 1.

TABLE 1

Material	Thickness (cm)	WET (cm)
Lead	4.5	25
Aluminum	11.9	25
Human Tissue (lung)	85.4	25
Water	25	25
Titanium	7	25
Stainless-steel	4.6	25

Table 1 shows the relative thickness of a material needed to achieve a WET characteristic of 25 cm. For example, lead having a thickness of about 4.5 cm will deplete the energy of a proton beam passing through it to the same degree as a tank of water with a thickness of 25 cm. Stainless-steel having a thickness of about 4.6 cm will deplete the energy of a proton beam passing through it to the same degree as a tank of water with a thickness of 25 cm.

[0077] Different materials may also have different scattering effects on proton beam **805**. For example, a quantity of lead with a particular thickness may scatter beam **805** to a greater degree than a quantity of stainless-steel with the same thickness.

[0078] In embodiments, material **818** may be stainless-steel and material **820** may be lead. Similarly, material **822** may be stainless-steel and material **824** may be lead. Because lead and stainless-steel have similar WET values, it may be convenient to use them together in modulator **800** to perform modulation. However, any material may be used to perform the modulation so long as the material thickness is chosen to achieve the desired energy dissipation.

[0079] As shown in FIG. 8, the overall thickness of material section **804** (which comprises material **818** and material **820**) tapers from relatively thick to relatively thin as angle θ increases. Similarly, the thickness of material **818** tapers from relatively thick to relatively thin as angle θ increases. Also, having an opposite taper, the thickness of material **820** tapers from thin to thick as angle θ increases.

[0080] If material section **804** consisted of a single type of material with varying thickness, then the energy level and the scattering effect of beam **805** may both vary as beam **805** traverses the single material. However, to achieve an accurate image from a proton beam imaging system, it may be desirable to vary the energy level of beam **805** while maintaining a relatively constant scattering of beam **805**. Providing two materials having different scattering effects may allow modulator **800** to achieve this goal.

[0081] As noted above, lead and stainless-steel have similar WET characteristics for dissipating energy from proton beam **805**. In contrast, lead and stainless-steel may have different scattering effects on beam **805**. Lead, for example, may provide more scattering than stainless-steel for a given thickness of material. As such, material section **804** may comprise both lead and stainless-steel sections. For example, as beam **805** passes through thick portion **814**, stainless-steel section **818** may provide a relatively large amount of energy dissipation and scattering. As beam **805** passes through thin portion **816**, stainless-steel section **818** may provide a relatively small amount of energy dissipation and scattering. Lead section **820**, which may provide more scattering per cm of thickness than stainless-steel, may be relatively thicker at end **816** to compensate for the lack of scattering

at end **816**. Thus, the combination of materials may provide reduced energy dissipation and relatively constant scattering as angle θ increases.

[0082] As noted above, beam **805** may pass through both material sections **804** and **806**. Thus, beam **805** may pass through stainless-steel section **818**, lead section **820**, lead section **824**, and stainless-steel section **822** as it passes through modulator **800**. The effects of these sections on beam **805** may be additive. For example, if at a given point where beam **805** is passing through the modulator, the thickness of stainless-steel section **818** is 1 cm and the thickness of stainless-steel section **822** is 1 cm, the energy dissipation and scattering effect provided by these two sections may be the same or similar to a single stainless-steel section with 2 cm thickness. The same additive characteristic may be true for lead sections **820** and **824**. Thus, the sum of the thicknesses of material sections **818**, **820**, **822**, and **824** may be chosen so that the sections, in combination, provide the desired modulation and scattering effects.

[0083] Although modulator **800** is shown with stainless-steel sections positioned along the outside circumference and lead sections positioned closer to axis of rotation **802**, any placement of the materials may be used to achieve the desired dissipation and scattering effects. For example, the lead sections could be placed along the outside circumference and the stainless-steel sections could be placed closer to axis of rotation **802**. Also, although the stainless-steel and lead sections are shown in direct contact with one another, in other embodiments there may be an air gap between the lead and stainless-steel sections. Additionally, although stainless-steel and lead are used as example materials, other materials may also be used to achieve the desired dissipation and scattering effects. In each of these alternate embodiments, the thickness of each material section may be altered and/or chosen so that the desired dissipation and scattering effects are achieved.

[0084] In embodiments, material sections **804** and **806** need not be wedge-shaped. Other shapes (such as a sine wave shape, a triangle shape, etc.) may provide other modulation profiles if desired. In other embodiments, the thickness of material sections **804** and **806** is shown in the thickness profile of FIG. 10, which will be discussed below.

[0085] FIG. 9 is an exploded isometric view of a portion **900** of a modulator assembly **800** (FIG. 8). In an embodiment, modulator assembly **800** (FIG. 8) comprises an inner plate **902** (here shown as a wheel-shaped inner plate **902**) and an opposite, outer plate **904** (here shown as a wheel-shaped outer plate **904**). Wedge-shaped material sections **804** and **806** (which together form modulator **803**) are secured between plates **902** and **904**. It should be appreciated that inner and outer plates may be provided having any shape suitable to secure the modulator **803**.

[0086] In embodiments, wedge-shaped material sections **804** and **806** may be secured between plates **902** and **904** using any securing, mounting or fastening technique known to those of ordinary skill in the art. In the illustrative embodiment of FIG. 9, bolts **906** and **908** which pass through holes in plate **904** and material sections **804** and **806** are used. Bolts **906** and **908** may engage threaded holes in plate **902** and may be tightened to secure plates **902** and **904** and material sections **804** and **806** in desired positions. In embodiments, modulator **800** includes additional bolts or pins through material sections **804** and **806** so they do not pivot out of place. Bolts **906** and **908** may be made from the

same type of stainless-steel as material sections **818** and **822** so that they do not create inconsistencies in beam dissipation when beam **805** passes through bolts **906** and **908**.

[**0087**] Plate **902** may also include a hole **910** at the axis of rotation that can be used to mount modulator **800** on a motor spindle or shaft. A modular design such as the one shown in exploded view **900** may allow a user to easily swap components. For example, material sections **804** and **806** may be swapped for sections having other types of materials and shapes. Also, modulator assembly **800** (or just a modulator portion of a modulator assembly such as assembly **800**) may be de-coupled or otherwise removed from motor **801** and replaced with another modulator and/or modulator assembly which provides a different modulation profile if needed for a particular application.

[**0088**] FIG. **10** is a graph **1000** of material thickness versus scattering angle. The horizontal axis represents material thickness in cm. The vertical axis represents proton beam scattering angle in degrees. Curve **1002** is a scattering profile for stainless-steel and curve **1004** is a scattering profile for lead. As shown (and as discussed above) lead provides more scattering at a given thickness than stainless-steel. For example, 2 cm of lead causes approximately 3 degrees of scattering while 2 cm of stainless-steel causes approximately 1.5 degrees of scattering (see points **1006** and **1008**, respectively).

[**0089**] FIG. **11** is a graph **1100** that illustrates a thickness profile for material sections **818** and **820** (and/or material sections **822** and **824**). (See FIG. **8**). The horizontal axis represents the angle α and the vertical axis represents radial thickness in cm. Curve **1102** represents the thickness of stainless-steel section **818**. As angle α increases from 0 to 150, the thickness of section **818** increases linearly from about 0 cm to about 3.2 cm. Curve **1104** represents the thickness of lead section **820**. As angle α increases from 0 to 150, the thickness of section **818** decreases from about 0.7 cm to about 0 cm. In embodiments, curve **1104** may approximate an exponential decay. FIG. **11** illustrates thicknesses for one embodiment of modulator **800**. Other thicknesses and shapes may also be used.

[**0090**] FIG. **12** is a graph **1200** that illustrates a scattering effect (curve **1202**) for a modulator (e.g. modulator **800**) with the material thickness profile shown in graph **1100**. The horizontal axis represents the angle α and the vertical axis represents scattering angle of a proton beam passing through modulator **800** at angle α . As angle α increases, the proton beam scattering angle stays relatively constant at about 2.3 degrees.

[**0091**] FIG. **13** is a graph **1300** that illustrates proton beam energy modulation for a modulator (e.g. modulator **800**) with the material thickness profile shown in graph **1100**. The horizontal axis represents the angle α and the vertical axis represents the WET characteristic of modulator **800** as seen by a proton beam entering modulator **800** at angle α . As angle α increases (i.e. as the thickness of the material through which the proton beam passes increases), the WET characteristic of modulator **800** increases approximately linearly from about 10 WET to about 30 WET. In other embodiments, the WET characteristic of modulator **800** may range from less than about 12 WET to more than about 32 WET.

[**0092**] FIG. **14** is a graph **1400** of measured test results that illustrate Bragg peaks of a proton beam passing through modulator **800** during operation. In this example, after

exiting the modulator, the proton beam enters a tank of water (or, in this case, test equipment that simulates a tank of water). The horizontal axis represents the depth that the protons travel in the water tank. The vertical axis represents arbitrary units of energy released by the protons. As shown, as modulator **800** operates, Bragg peaks **1402** can be seen ranging between 0 cm and about 25 cm in the water tank. In other embodiments, Bragg peaks **1402** may range between about 12 cm WET to about 32 cm WET. Bragg peak **1404** corresponds to the unmodulated proton beam that passes through open channel **808** without passing through material section **804** or **806**. (See FIG. **8**). Thus, because they are unmodulated, the proton or protons that generate Bragg peak **1404** have a significantly higher energy level.

[**0093**] Having described various embodiments, which serve to illustrate various concepts, structures and techniques, which are the subject of this patent, it will now become apparent to those of ordinary skill in the art that other embodiments incorporating these concepts, structures and techniques may be used. Accordingly, it is submitted that that scope of the patent should not be limited to the described embodiments but rather should be limited only by the spirit and scope of the following claims. All references cited in this document are incorporated here by reference in their entirety.

1. A proton beam modulator comprising:

- a first modulating portion comprising a first material portion and a second material portion, the first and second materials provided having characteristics such that in response to a proton beam incident thereon, at least portions of the proton beam pass therethrough; and
- a second modulating portion comprising a third material portion and a fourth material portion provided having characteristics such that in response to the proton beam incident thereon, at least portions of the proton beam pass therethrough;

wherein the first and second modulating portions are symmetrically disposed about an axis of rotation of the proton beam modulator,

wherein the combination of the first, second, third, and fourth material portions modulate an energy level of the proton beam and a scattering of the proton beam, wherein the scattering remains substantially constant as the modulator rotates.

2. The proton beam modulator of claim **26** wherein the rotating wheel is positioned so that the proton beam passes through a center of rotation of the rotating wheel.

3. The proton beam modulator of claim **26** wherein the rotating wheel is positioned so that an axis of rotation of the rotating wheel is perpendicular to the proton beam.

4. The proton beam modulator of claim **1** wherein the first modulating portion and the second modulating portion are positioned to create an open channel through the modulator so that, when the channel is parallel to the proton beam, the proton beam can pass through the open channel without passing through the first and second modulating portion.

5. The proton beam modulator of claim **1** wherein the first modulating portion has a wedge shape.

6. The proton beam modulator of claim **5** wherein the first material portion and the second material portion are arranged radially from the axis of rotation so that the second material portion is inside the first material portion.

7. The proton beam modulator of claim 5 wherein a thickness of the wedge shape decreases along an angular coordinate of the wedge shape.

8. The proton beam modulator of claim 7 wherein a thickness of the first material portion decreases along the angular coordinate of the wedge shape and a thickness of the second material portion increases along the angular coordinate of the wedge shape.

9. (canceled)

10. The proton beam modulator of claim 1 wherein the combination of the first, second, third, and fourth material portions modulate the energy level of the proton beam such that the energy level of the proton beam changes as the modulator rotates.

11. The proton beam modulator of claim 1 wherein the first and second modulating portions produce an energy modulation in the range of about 12 cm WET to about 32 cm WET.

12. (canceled)

13. The proton beam modulator of claim 26 further comprising a circular plate positioned so that the first modulating portion and the second modulating portion are sandwiched between the rotating wheel and the circular plate.

14. The proton beam modulator of claim 13 wherein the first and second modulating portions are removable from the rotating wheel and the circular plate.

15. The proton beam modulator of claim 1 wherein the first and third material portions comprise stainless-steel.

16. The proton beam modulator of claim 1 wherein the second and fourth material portions comprise lead.

17. The proton beam modulator of claim 26 wherein the rotating wheel has a diameter of 10 cm or less.

18. The proton beam modulator of claim 1 wherein: the first and third material portions comprise a first type of material;

the second and fourth material portions comprise a second type of material; and

the second material portion is positioned between the first material portion and an axis of rotation of the proton beam modulator, and the fourth material portion is positioned between the third material portion and the axis of rotation of the proton beam modulator.

19. A proton beam imaging system comprising: a proton beam generator to generate a proton beam; a proton beam modulator through which the proton beam passes positioned between the proton beam generator and an image target; and a proton beam detector positioned to detect the proton beam exiting the image target;

wherein the proton beam modulator comprises: a rotating wheel having an axis of rotation positioned so that the proton beam passes through the axis of rotation and the axis of rotation is perpendicular to the proton beam;

a first modulating portion comprising a first material portion and a second material portion through which a proton beam passes; and

a second modulating portion comprising a third material portion and a fourth material portion through which the proton beam passes;

wherein the first and second modulation portions are positioned opposite each other on the rotating wheel, wherein the first, second, third, and fourth material portions comprise a wedge shape having a varying thickness to modulate an energy level of the proton beam as the proton beam modulator rotates, wherein the proton beam is modulated to have a substantially constant degree of scattering as the proton beam modulator rotates.

20. The proton beam imaging system of claim 19 wherein the first and third material portions comprise stainless-steel, and the second and fourth material portions comprise lead.

21. (canceled)

22. (canceled)

23. The proton beam imaging system of claim 19 further comprising a gantry portion, wherein the proton beam modulator is situated within the gantry portion.

24. A proton beam modulator comprising:

a plurality of wedge-shaped modulating portions, each of the plurality of wedge-shaped modulating portions comprising a first material portion and a second material portion disposed on a surface of the wedge-shaped modulating portions such that in response to a proton beam incident thereon, at least portions of the proton beam are capable of passing therethrough and wherein the plurality of wedge-shaped modulating portions are disposed in spatial relation such that the plurality of wedge-shaped modulating portions define an axis of rotation positioned such that an axis along which a proton beam is aligned is perpendicular to the axis of rotation defined by the plurality of wedge-shaped modulating portions,

wherein the first material portion and the second material portion are arranged radially from the axis of rotation so that the second material portion is inside the first material portion.

25. The proton beam modulator of claim 24 wherein the plurality of wedge-shaped modulating portions are provided as a pair of modulating portions positioned opposite each other to define an axis of rotation positioned such that an axis along which a proton beam is aligned is perpendicular to the axis of rotation defined by the pair of wedge-shaped modulating portions.

26. The proton beam modulator of claim 1 further comprising a rotating wheel whereupon the first and second modulating portions are positioned opposite each other.

* * * * *